

Control Module Installation

for MD 30-2500



CORPORATION

219-482-4204

505 Ley Road Fort Wayne, IN 46825

IN PANEL MOUNTING

Vortec offers a variety of Trim Bezels for mounting the Vortec Engine Idler and the Vortec Voltage Monitor in the Panels of your vehicle.

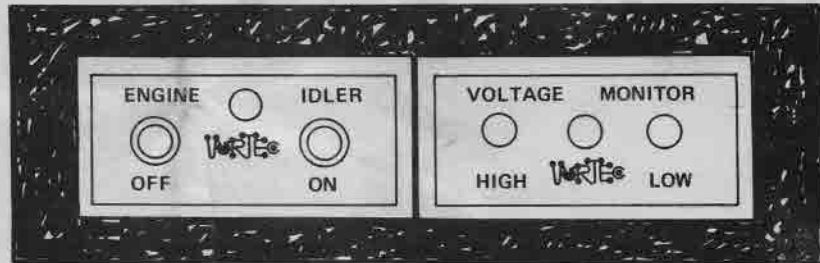

TRIM BEZEL 1.5" x 4.75" (MD 30-003)

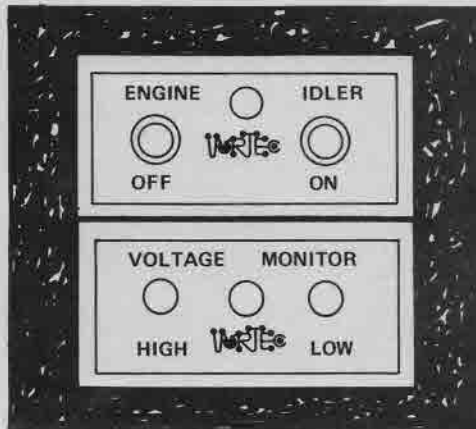

TRIM BEZEL 2.5" x 2.75" (MD 30-004)



TRIM BEZEL 1.5" x 2.75" (MD 30-002)

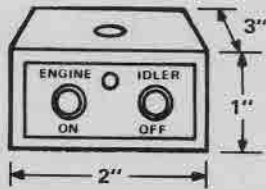

UNDER THE DASHBOARD MOUNTING

MOUNT WITH 8-32 X 2 1/2" SCREW

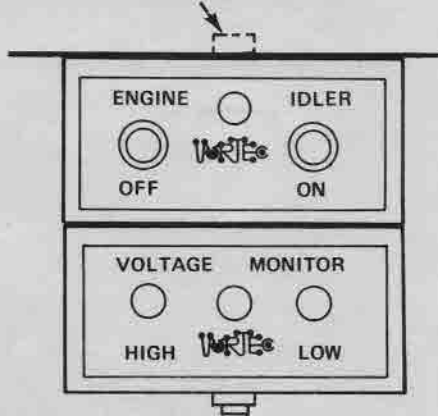

MOUNT WITH 8-32 X 1 1/2" SCREW

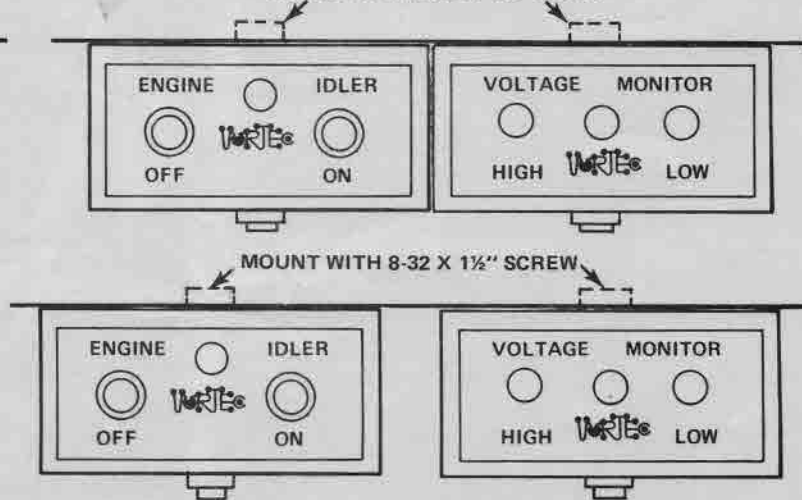

UNIVERSAL WIRING DIAGRAM

for MD 30-2500



CORPORATION

219-482-4204

505 Ley Road Fort Wayne, IN 46825

WIRING DIAGRAM

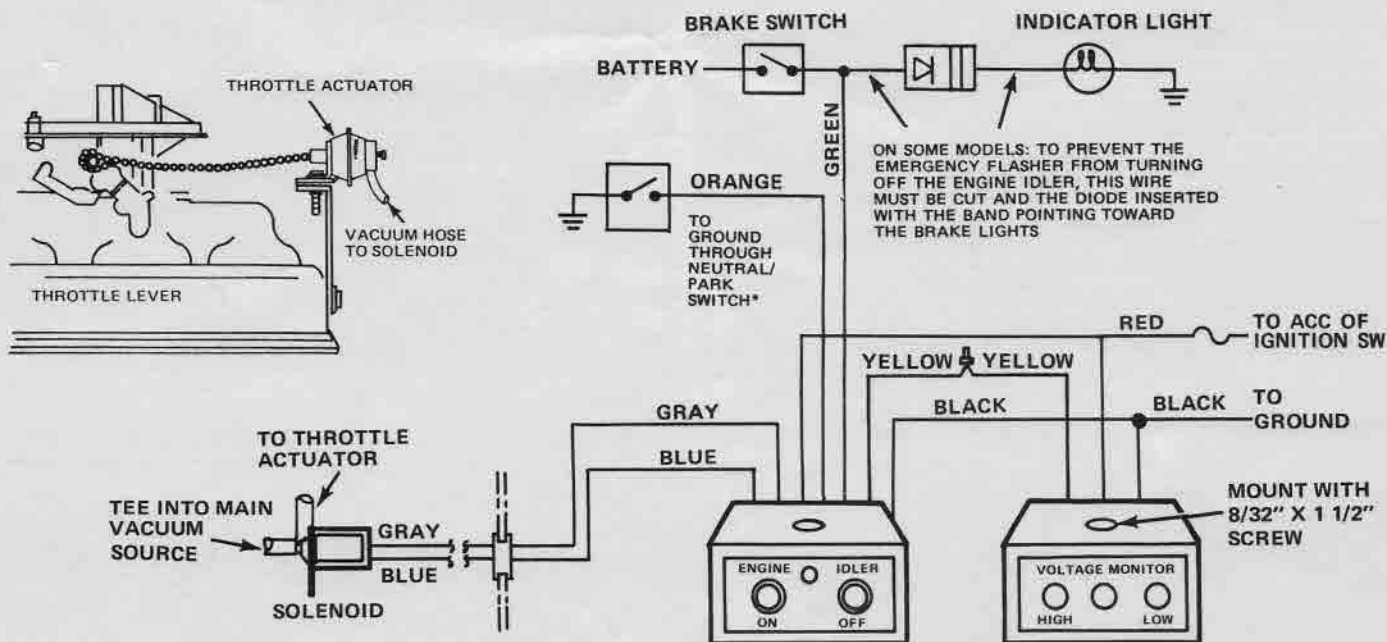

TEST PROCEDURE

1. With the transmission in PARK turn on the ignition switch, but do not start the engine. The LIGHT on the Engine Idler should remain OFF.
2. Press the ON switch on the Engine Idler. The LIGHT should turn ON.
3. Move the transmission selector to REVERSE. The LIGHT should turn OFF.
4. Repeat step 2.
5. Depress the BRAKE pedal. The LIGHT should turn OFF.
6. START the engine and allow it to warm up with the transmission in PARK.
7. Depress the ON switch and adjust the THROTTLE ACTUATOR adjustment screw to obtain the desired engine RPM. Recheck the speed setting by turning the unit OFF and ON a few times.
8. Connect the yellow wire from the Engine Idler to the Voltage Monitor (if purchased). Automatic actuation will occur whenever the low voltage indicator light remains on for approximately 10 seconds.

THROTTLE ACTUATOR

- Mount the throttle actuator ① in a position that will allow free movement of the ball chain between the throttle lever and the throttle actuator. Examples of mounting techniques are shown in FIGS. 1, 2 and 3.

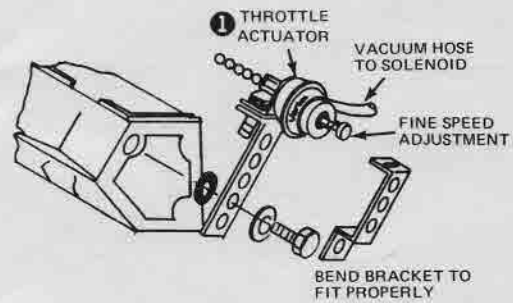

FIG. 1

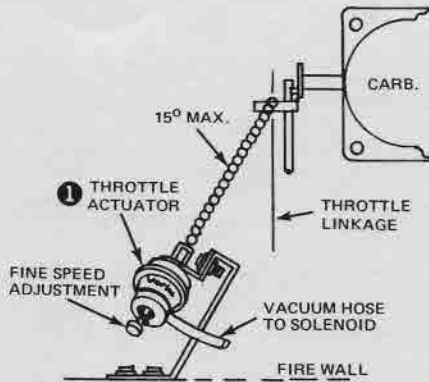

FIG. 2

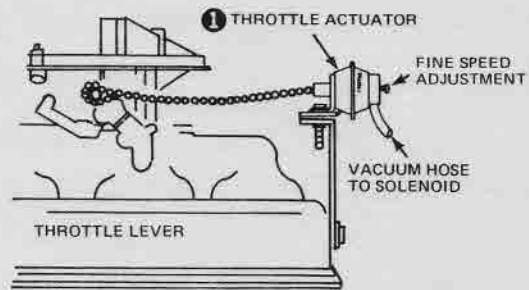

FIG. 3

- The coarse speed adjustment should be made as shown in FIG. 4

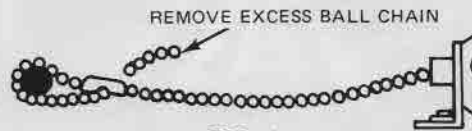

FIG. 4

- The fine speed adjustment will be made after the engine is running with the thumb screw adjustment.
- Check for proper installation by manually activating the throttle actuator (see FIG. 5) and completely opening the throttle (see FIG. 6).

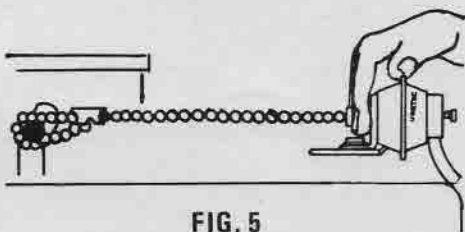

FIG. 5

CAUTION
Be sure the chain is free to move and does not catch any other parts or restrict throttle movement when the throttle is opened or closed or the throttle actuator is manually depressed.

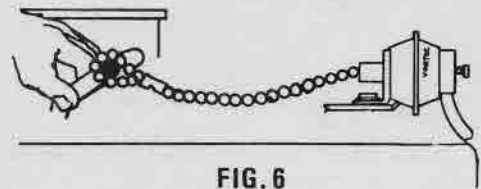

FIG. 6

SOLENOID

- Mount the Solenoid ② in a position that will allow the vacuum hose to be teed into the main vacuum source (see FIG. 7).

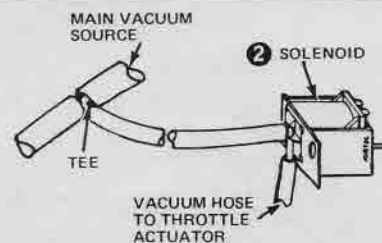
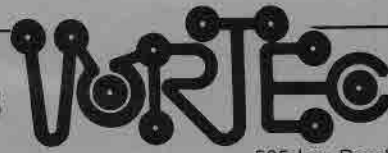

FIG. 7

Engine Components Installation Instructions

for FORD 460 Cu. In. V8



CORPORATION

219-482-4204

505 Ley Road, Fort Wayne, IN 46825

1. Mount the throttle actuator ① with the left bolt which secures the throttle bracket to the intake manifold.
2. Mount the vacuum valve ② to the side of the throttle bracket using the prepunched holes in the side of the bracket and the two 10 x 32 x 1/2" screws ③ supplied in the #1 packet.
3. Cut main vacuum source hose and insert vacuum tee ④.
4. Connect the vacuum hoses ⑤ as shown to the vacuum valve. (If the hose connections are reversed, the unit will not operate properly.)
5. Pop the throttle cable off of the ball stud at the carburetor and make the coarse speed adjustment ⑥ as shown in FIG.1. Adjust so the chain has approximately 1/4" to 3/8" of slack when the choke is off and the throttle is completely closed. Now put the loop of the ball chain ⑦ over the stud and reconnect the throttle cable.

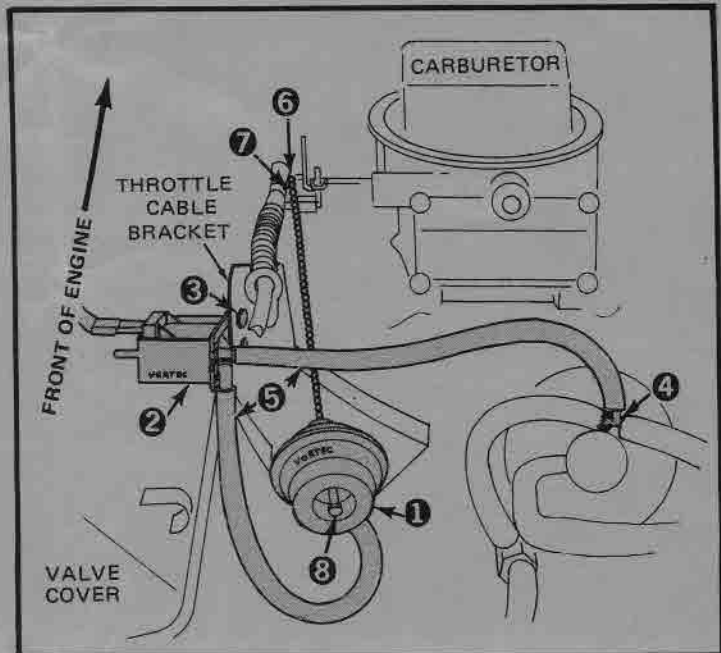

ENGINE COMPONENTS INSTALLED ON FORD 460

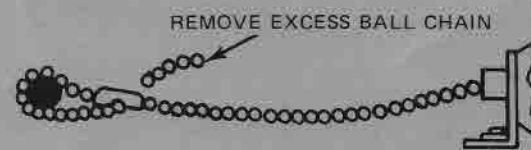

FIG. 1 COARSE RPM ADJUSTMENT

6. The fine speed adjustment ⑧ will be made after the engine is running with the thumb screw adjustment.
7. Check for proper installation by manually activating the throttle actuator (see FIG.2) and completely opening the throttle (see FIG.3).

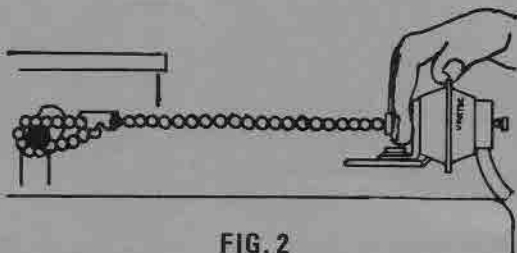

FIG. 2

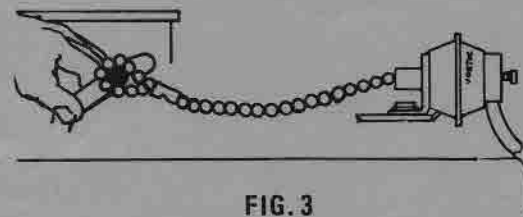

FIG. 3

CAUTION

Be sure the chain is free to move and does not catch any other parts or restrict throttle movement when the throttle is opened or closed or the throttle actuator is manually depressed.

INSTALLATION

The Orange wire from the Vortec throttle control module should be wired to the Ford Neutral/Park circuit as follows:

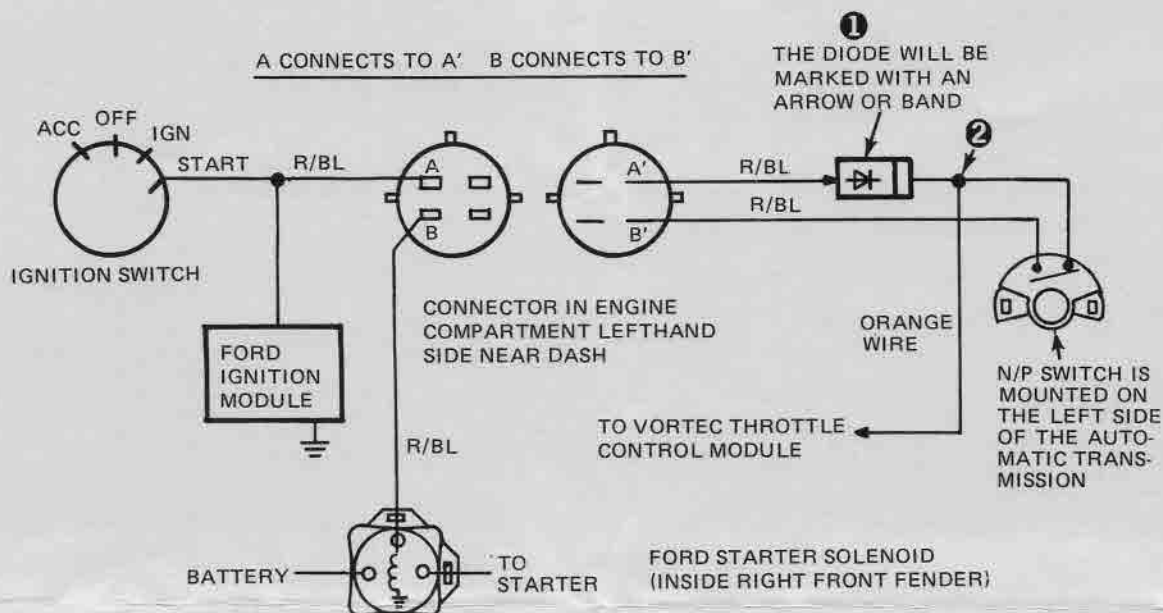

The diode ① must be installed in the proper Red/Blue (R/BL) wire and have the band on the diode towards the N/P switch in order for the throttle control module to work properly. The Orange ② wire must be connected to the banded side of the diode.

TO FIND THE PROPER (R/BL) WIRE

If it is difficult to trace which (R/BL) striped wire goes to point A on the connector, perform the following test.

1. Put the transmission in Drive.
2. Connect one end of a test light to +12V.
3. Pierce the insulation of the two R/BL wires with the test light probe.
4. The diode should be inserted in the wire which makes the test light burn dim or not at all.

HOW IT WORKS

Vortec throttle devices are designed to operate only when the vehicle is in park or neutral. The control module senses that the vehicle is in park or neutral whenever the Orange wire detects an electrical path to ground. (The diode prevents the Orange wire from seeking a ground path through the Ford ignition model.)